



INSTRUCTION MANUAL

MODEL 942B

MAGNETIZER

Starting with Serial Number 41807

Created -2013

8431 Castlewood Drive, Indianapolis, IN 46250 USA
(317) 842-7500 • Fax (317) 849-7600
E-Mail: maginst@maginst.com • www.maginst.com

IMPORTANT

THE FIXTURE MUST BE CONNECTED BEFORE TURNING ON THE
MAGNETIZER. THE MAGNETIZER WILL NOT FUNCTION UNLESS
A FIXTURE IS PROPERLY CONNECTED.

BEFORE FIRST USE, INSPECT THE MACHINE AND MAGNETIZING
FIXTURE CAREFULLY FOR ANY SIGNS OF SHIPPING DAMAGE.
IF DAMAGE IS EVIDENT NOTIFY THE CARRIER AND MAGNETIC
INSTRUMENTATION, INC. IMMEDIATELY.

THE INSTALLATION, OPERATION AND MAINTENANCE OF THIS
EQUIPMENT SHOULD BE PERFORMED BY QUALIFIED PERSONS
ONLY.

WARNING:

The equipment herein described contains high voltage.
Exercise due care during operation and servicing.
Read safety summary on the following pages.

SAFETY SUMMARY

The following safety precautions must be observed at all times during operation, service and repair of this product. Failure to comply with these precautions, or with specific warnings elsewhere in this manual, violates safety standards of design, manufacture, and intended use of this product. Magnetic Instrumentation, Inc. assumes no liability for failure to comply with these requirements.

GROUND THE EQUIPMENT

To minimize shock hazard, chassis, cabinets, and equipment racks must be connected to an electrical ground. AC powered products are equipped with a three-connector power cable, or equivalent connection on a terminal block. Power cables must be plugged into an approved three-contact adapter with the grounding wire (green) firmly connected to an electrical ground (safety ground) at the power outlet. The power jack and mating plug of power cables provided meet International Electromechanical Commission (IEC) safety standards. Equipment provided with terminal blocks, operating from either AC or DC is provided with appropriate means for connecting an electrical safety ground.

DO NOT OPERATE IN AN EXPLOSIVE ATMOSPHERE

Do not operate the product in the presence of flammable gases or fumes. Operation of any electrical equipment in such an environment constitutes a definite safety hazard.

DO NOT OPERATE IN WET OR DAMP AREAS

Do not operate the product in wet or damp areas. Operation of any electrical equipment in such an environment constitutes a definite safety hazard.

KEEP AWAY FROM LIVE CIRCUITS

Operating personnel must not remove covers. Replacement of components and internal adjustments must be made by qualified maintenance persons. Disconnect power cable when replacing components. Under certain conditions, dangerous voltages may exist even with the power cable disconnected. To avoid injuries always disconnect power and discharge circuits by grounding before touching them.

DO NOT SERVICE OR ADJUST ALONE

Do not attempt internal service or adjustment unless another person capable of rendering first aid and resuscitation is present.

DO NOT SUBSTITUTE PARTS OR MODIFY EQUIPMENT

Because of the danger of introducing additional hazards, do not install substitute parts or perform an unauthorized modification to the equipment. The product may be returned for service and repair to ensure that safety features are maintained.

DANGEROUS-PROCEDURE WARNING

Throughout this manual, warnings identify potentially dangerous procedures. Instructions contained therein must be followed.

TABLE OF CONTENTS

I. GENERAL DESCRIPTION	1
A. Optional Accessories	2
B. Safety Procedures	2
II. ELECTRONICS CABINET	3
A. Specifications	3
B. Control Panel Components	3
C. Magnetizing Fixture and Connections	5
III. SET UP INSTRUCTIONS	6
IV. BASIC MAGNETIZER CIRCUIT DESCRIPTION	7
A. Capacitor Charging Circuit	7
B. Discharge Circuit	8
C. Current Bias Supply	8
D. Safety Drain Circuit	8
V. CIRCUIT BOARD DESCRIPTIONS	9
A. General Description of Charge Control Board # 10420270	9
B. Technical Description of Charge Control Board # 10420270	9
C. General Description Power Supply and Relay Board # 10401433	11
D. General Description of $\pm 15\text{VDC}/\pm 24\text{VDC}$ Power Supply # 10401415	11
E. Technical Description of $\pm 15\text{VDC}/\pm 24\text{VDC}$ Power Supply # 10401415	12
F. General Description of Relay Board # 10401416	12
G. Technical Description of Relay Board # 10401416	12
H. Description of 3000 / 300 Divider Board # 10407715	14
I. Technical Description of 3000 / 300 Divider Board # 10407715	14
J. General Description of Parallel SCR Driver Board # 10412049	14

K.	Technical Description of Parallel SCR Driver Board # 10412049	14
VI.	SERVICE AND MAINTENANCE	16
A.	General Instructions	16
B.	Test Equipment	16
C.	Panel Removal	17
D.	Adjustments	17
E.	Trouble Shooting	17
VII.	REPLACEMENT PARTS	19

I. GENERAL DESCRIPTION

The Model 942B is a high voltage, capacitive discharge-type magnetizer capable of saturating all alnico, ferrite, and rare earth magnetic materials. The Model 942B is easily adapted to a wide variety of production and laboratory magnetizing requirements.

Solid state electronic control circuitry makes this magnetizer a highly reliable, low maintenance unit. The electronic voltage control circuit prevents the unit from being discharged before the preset energy level has been reached, thereby preventing incomplete magnetization.

The Model 942B, with all electronic circuitry and capacitors enclosed in the cabinet, is also designed for maximum operator safety when used with Magnetic Instrumentation, Inc. Magnetizing Fixtures. An interlock switch is ~~also mounted with~~ to the panel covering the connections for the Magnetizing Fixture on the table top. The removal of a Magnetizing Fixture ~~breaks the incoming power to the control circuits and engages a safety drain circuit that discharges any energy stored in the capacitor bank.~~

A ~~2 terminal twist-lock CHARGE~~ charge INTERLOCK ~~interlock~~ socket (Figure 6) is provided on the side of the chassis containing the Magnetizing Fixture ~~transformer~~ connections on the table top. This allows for connection of an external interlock switch, engaged with the closure of ~~safety shields~~, or Magnetizing Fixture covers to be sure they are properly closed before the operator can charge the capacitors.

The Model 942B Magnetizer is available in four basic models, depending upon the capacitance of the ~~capacitor bank~~.

Model	Capacitance
942B-2	200 μ F
942B-4	400 μ F
942B-6	600 μ F
942B-8	800 μ F

Any of these models may be operated from either a 115 VAC or 230 VAC power line.

The ~~power supply~~ Magnetizer draws a maximum current of 15 Amperes at 115 VAC, and it charges a 200 μ F capacitor bank to 3000 Volts in about 2 seconds. As additional capacitors are added, the charging time is increased proportionally.

Formatted: Not Highlight

Formatted: Not Highlight

Formatted: Not Highlight

Formatted: Not Highlight

Formatted: Not Highlight

A. Optional Accessories

Foot Switch

The Foot Switch option (P/N: 09912508) provides for external control of the eCharge or Magnetize functions. Other provisions for remote operation are available.

Temperature Monitor

The Temperature Monitor option (P/N: 09003126) will continuously display the

Formatted: Tab stops: -0.5", Left

B. Safety Procedures

This equipment operates at high voltage. All high voltage windings and connections are enclosed in the cabinet and Magnetizing Fixture housing. Under no circumstances should these housings or the cabinet be tampered with, or the design altered unless previously discussed with Magnetic Instrumentation, Inc. Care should be taken that the equipment is properly grounded. No drilling, tapping, or machine work should be done on the Magnetizing Fixture housing unless drawings of the internal construction are first obtained from Magnetic Instrumentation, Inc.

An interlock is mounted to the panel covering the disconnect jacks for the Magnetizing Fixture. This prevents operation of the machine without the Magnetizing Fixture properly attached. The high voltage disconnect jack and the four side panels should only be removed are provided with interlocks that break the power line. These interlocks should be blocked only for troubleshooting purposes and then only by an engineer or skilled technician familiar with this type of equipment and with the danger involved with working with several hundred microfarads of capacitance charged to 3000 volts.

Caution labels are placed on the equipment in strategic locations, to alert the possible safety hazards. For maximum safety to the operator, all safety precautions indicated or implied must be observed.

II. ELECTRONICS CABINET

A. Specifications

Power Source	115 or 230 Volts, 50/60 cycles. 15 Amperes maximum.
Storage Capacitors	200 μ , 400 μ , 600 μ , or 800 μ F, as ordered. Up to 800 μ F may be installed in the cabinet on initial order, or later as required.
Output Voltage	100 Volts to 3,000 Volts (set by user)
Watt-Second Ratings (Joules)	200 μ F capacitor bank: 900 watt-seconds. 400 μ F capacitor bank: 1800 watt-seconds. 600 μ F capacitor bank: 2700 watt-seconds. 800 μ F capacitor bank: 3600 watt-seconds.
Dimensions and Weight	Size: 31" wide x 39" long x 34" high. Weight: 350 pounds for 200 μ F unit, 600 pounds for 800 μ F unit, (Not including Magnetizing Fixture)

B. Control Panel Components

Power ON-OFF Switch

This 15 Amp circuit breaker controls power into the machine.

Fuse

This 1/2 A Slow-Blow 3AG fuse protects the control circuitry.

Power On Light

This red power On / Off light indicates main control power is on.

Panel Meter

The panel meter is a 0 to 1 milli-amp analog meter. It continuously monitors the voltage of the energy storage capacitor bank. Resistors located on the power supply chassis inside the machine limit the current to the meter so that it displays 0 to 3000 volts.

Voltage Control

This 10 turn potentiometer is used to control the voltage to which the energy storage capacitor bank is charged. Voltage may be increased by turning the knob clockwise. Voltage may be decreased by turning off the power-on switch (circuit breaker) or by initiating the Magnetize function, thereby discharging the capacitor bank through the fixture. NOTE: When initially setting the voltage it is best to start with the voltage control knob at minimum and slowly adjust this control clockwise so as not to overshoot the desired level.

Function Select Switch

Manual (Center Position)

In this mode of operation, manual initiation of both the Charge and Magnetize function is required. Press the Charge push-button when the white ready-to-charge light is on. The magnetizer will charge to the voltage level set by the Voltage Control knob and the green ready-to-magnetize light will turn on. Voltage may be increased by turning the Voltage Control knob clockwise, or the magnetizer may be discharged by pressing the Magnetize push-button, provided the green ready-to-magnetize light is illuminated.

Auto Magnetize (Down Position)

In this mode of operation the charge function must be initiated by pressing the Charge push-button. Upon reaching the voltage level set by the Voltage Control knob the magnetizer will automatically discharge.

Auto Charge (Up Position)

In this mode of operation the magnetizer will automatically charge to the voltage level set by the Voltage Control knob and maintain this level until the Magnetize push-button is pressed. After a period of “off time” the magnetizer will recharge automatically and be ready for the next cycle.

Charge Light

Illumination of the white light indicates that the magnetizer is ready-to-charge.

Charge Push-Button

The Charge push-button is active only when the magnetizer is ready-to-charge as indicated by the white light. Pressing the Charge push-button will cause the machine to charge to the level set by the Voltage Control knob.

External Charge

Directly beneath the Charge push-button is the external charge socket. A dry contact closure between the 2 terminals will provide a Charge input. (The same as pressing the Charge push-button.)

Magnetize Light

Illumination of the green light indicates that the magnetizer is ready-to-magnetize.

Magnetize Push-Button

The Magnetize push-button is active only when the magnetizer is ready-to-magnetize. Pressing the Magnetize push-button will cause the machine to discharge the stored energy into the Magnetizing Fixture.

External Magnetize

Directly beneath the Magnetize pushbutton is the external magnetize socket. A dry contact closure between the 2 terminals will provide a Magnetize input. (The same as pressing the Magnetize push-button.)

C. Magnetizing Fixture and Connections

To install a Magnetizing Fixture on the Magnetizer, place the fixture on the table top so that the pins on the fixture line up with the sockets on the machine. Firmly push the Magnetizing Fixture straight into the sockets until no air gap is seen and the Fixture connected interlock switch engages.

IMPORTANT: When connecting a Magnetizing Fixture to the Magnetizer, observe the connection pins and fixture housing for signs of wear. Connecting a fixture that has a badly worn housing may pose a hazardous condition to the operator. Make sure the connections are firmly seated. A poor connection may cause electrical arcing and/or a low magnetizing field within the fixture.

Magnetizing Fixtures are available from Magnetic Instrumentation, Inc. for use with the Model 942B Magnetizer. Be sure to follow the suggested operating parameters for each fixture. Failure to do so may lead to premature failure of the Magnetizer and /or the Magnetizing Fixture.

NOTE: Due to the high amount of magnetic field produced in the Magnetizing Fixture, it is important to position the part to be magnetized carefully. A improperly positioned part will be exposed to a high force moving the part towards the location of maximum field. Properly locating the part will prevent it from being launched or the possibility of a pinch point. Part locators for Magnetizing Fixtures are available from Magnetic Instrumentation, Inc. and are recommended for use with Magnetic Instrumentation, Inc. Magnetizing Fixtures.

III. SET UP INSTRUCTIONS

The following procedure verifies proper operation of the machine.

1. Place the electronics cabinet and Magnetizing Fixture in their final operating location.
2. Connect water source to the Magnetizing Fixture, if required.
3. Connect the Magnetizing Fixture to the electronics cabinet.
4. Set Voltage Control at minimum voltage (full counter-clockwise), and function select switch to Manual (center) position.
5. Connect AC power cord to a grounded power outlet capable of supplying 15 amps of continuous power.
6. Turn on electronics cabinet power switch.
7. The fan, the red Power On light, and the white Ready-to-Charge light should come on.
8. Press the Charge push-button. The machine will charge to approximately 100 volts and the green Ready-to-Magnetize light should come on.
9. Press the Magnetize push-button. The Magnetizer will discharge through the Fixture and remain idle for approximately 2 to 90 seconds.
10. After this period of off-time the white Ready-to-Charge light will come back on, allowing the cycle to be reinitiated.
11. Press the Charge push-button and slowly increase the Voltage Control until desired working voltage is reached.

The machine is now ready to begin processing parts.

IV. BASIC MAGNETIZER CIRCUIT DESCRIPTION

A Capacitive Discharge Magnetizer functions by supplying large amounts of energy in a short time to a Magnetizing Fixture. This magnetizing pulse is milliseconds in length and is drawn through a discharge switch from the capacitor bank. The capacitor bank is charged by drawing small amounts of power from the power line over several seconds. The basic magnetizer consists of a capacitor charging and discharging circuit both of which are controlled by the logic circuit within the cabinet. A current bias supply is provided for use with current transformers to make use of the maximum possible flux change and, therefore, the greatest energy transfer for each size of current transformer.

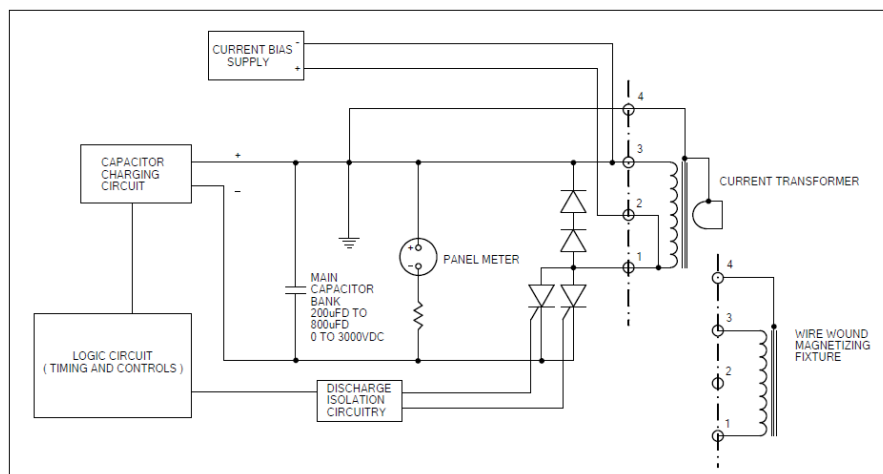

Block diagram of the Model 942B Magnetizer

Note: All of the major components' circuit designations in the following section of this manual are in bold and correspond to the Electrical Schematics sheet 4 and 5 of the drawing set.

A. Capacitor Charging Circuit

The capacitor charging circuit consists of a Solid State Relay (**ISSR**), Current Limiting Inductors (**1L and 2L**), Step-up Transformers (**1T and 4T**), Rectifier Boards (**1SA and 2SA**), and the Capacitor Bank (**1C thru 8C**). The charging circuit is controlled by the Solid State Relay providing primary power to the Step-up Transformers through the Current Limiting Inductors. The secondary voltage of these transformers is rectified by the Rectifier Boards that are connected directly to the Capacitor Bank.

B. Discharge Circuit

The discharge circuit, which provides the magnetizing current, consists of an electrically matched Parallel SCR Assembly (**1SCR**), Parallel SCR Driver Board (**4PCB**), Reverse Current Blocking Diode Assembly (**1DDP**), and the Magnetizing Fixture. Provided the Capacitor Bank is charged to the preset voltage level and the Magnetize function has been initiated, the Control Circuitry sends a logic signal to the Parallel SCR Driver Board. This circuit board gates both SCRs with a conditioned signal allowing the stored energy in Capacitor Bank to discharge through the Magnetizing Fixture. The Reverse Current Blocking Diode provides a circulation path for the collapsing current preventing any reverse current from flowing through the Magnetizing Fixture.

C. Current Bias Supply

The current bias supply is used when the Magnetizing Fixture is a Current Transformer. This supply provides current in the primary windings of the Current Transformer. The direction of current is reverse to that of the magnetizing current. This is to bias the steel core if the transformer magnetically so that the greatest possible flux change may be transferred from primary to secondary. This supply consists of transformer (**2T**), rectifier diode (**11D**), filter capacitor (**10C**), inductor (**3L**), and resistor (**7R**).

D. Safety Drain Circuit

The safety drain circuit will safely discharge the energy storage capacitor bank when the power to the machine is turned off or the Magnetizing Fixture is disconnected. Once the discharging of the capacitor bank begins, the machine will not operate until the voltage has decreased to a safe level. The drain circuit consists of a high voltage vacuum relay (**CRD**) and associated capacitors (**12C, 13C, and 14C**) and diodes (**12D and 13D**), two 10 K ohm 50 watt resistors (**3R and 4R**), and lockout relay (**1CR**). The contacts of the vacuum relay are normally closed and will connect the 10K resistors across the capacitor bank when the relay is not powered. The capacitors on the vacuum relay's coil provide a delay of about 4 seconds before the relay will turn off so that momentary interruptions of power will not effect machine operation. Once the draining of the capacitors begins lockout relay (**1CR**) engages and its contacts open removing power to the charge push button.

V. Circuit Board Descriptions

The following technical descriptions are for the circuit boards located within the Magnetizer. See the schematics for complete details.

A. General Description of Charge Control Board # 10427655

This board controls the charging, discharging, and timing of the machine.

The charging circuit uses a comparator IC, and Transistor Logic to control an externally mounted Solid State Relay. This Solid State Relay is used to control the primary of the step-up transformers used for charging the capacitor bank.

The discharge timing circuit uses a 3-Timer (IC's) Chain that is controlled by an external relay. The timing sequence provides enough time to allow the charge circuit to become inactive before discharging the capacitor bank. Actual discharge of the capacitor bank is not performed by this board, but it does provide a logic signal that starts the Parallel SCR Driver board which in turn gates the SCRs.

B. Technical Description of Charge Control Board # 10427655

Charge Circuit:

The reference voltage from the capacitor bank 0 to -300 vdc, is connected to pin 1 of the header connector, and is fed through a voltage divider R327 1 Meg ohm and R323 15K ohm to the inverting input of comparator AR301, pin 3. A reference from voltage control circuit, pins 23 & 24 of header connector, is fed through R324, 430 Ω , to the non-inverting input of comparator AR301. These two inputs are negative with respect to circuit and chassis ground. The output of AR301, pin 7, will be low, zero volts, when the capacitor bank reference voltage is below the level set by the voltage control circuit, or high, +15V if the capacitor bank is above the level set by the voltage control circuit. Hysteresis of this comparison is controlled by R325, 200K. Transistor Q308 is used to buffer and invert the output of AR301.

The collector of Q308 feeds two circuits:

1. Q307 inverts the logic level on the collector of Q308. The collector of Q307 is used to drive Q303 that makes up half of the two transistor “AND” circuit that enables a magnetize condition. Q303 must be on, signifying the capacitor bank is not charging, before the collector of Q302 will be allowed to go low upon the initiation of the magnetize signal (+15V applied to Pin 17 of header connector). This assures that the capacitor bank is at the correct voltage level and is not charging before allowing the magnetize or discharge function to be processed.
2. Q308 also drives the circuit that provides the control signal to the Solid State Relay, (providing primary power to the charging transformers) from Pin 7 of the header connector. To enable a charge condition, ground (supply common) must be applied to Pin 6 of the header connector, allowing the collector of Q311 to go low. A low level on the collector of Q311 turns on Q313 allowing the +24V supply to be seen through R333 and D305 (jumper wire) to Pin 7 of header connector. When Q313 is off the -24V supply through R334, R333, and D305 (jumper wire) creates a slightly negative potential at Pin 7 of header connector holding the Solid State Relay off. Q309 is used to drive an at-voltage (ready to magnetize indicator or relay coil) signal. If ground (supply common) is applied to Pin 8 of the header connector (emitter of Q309), and the -24V supply through a relay coil or an indicator is applied to Pin 5 of header connector, this coil/indicator will be on when Q313 is off.

Discharge Circuit:

Pin 17 of the header connector is used to initiate the discharge function. When the +15VDC supply is applied to Pin 17 of the header connector Q302 will be turned-on and provided Q303 is on, (signifying the charge circuit is not-active), ground (supply common) is seen at Pin 12 of header connector. Pin 12 of header connector is used to start the discharge timing sequence.

When Pin 12 of the header connector goes low, 2 conditions have happened.

1. The capacitor bank has been charged to the preset voltage level and the charge function is not currently active.
2. A magnetize input signal has been provided.

At the same time Pin 12 of the header connector goes low, Q310 is turned on holding Q313 (charging transistor) off, disabling the charge function. The 3-Timer Chain IC301, IC302, IC303 is enabled by Pin 10 of header connector, (Ov on Pin 10 = Disable +15V on Pin 10 = Enable), and triggered by Pin 19 of header connector (Ov = trigger).

Timing sequence:

Provided the timers are enabled, (Pin 10 of header connector at +15V), a low (0v) applied to Pin 19 of header connector turns off Q301 allowing C303 to discharge. This starts timers IC301 and IC 302. IC301 turns on Q304 disabling the charge circuit through Q310, and maintains the low at Pin 12 of header connector. IC301 also turns on Q305 activating the first half of a two transistor “AND” circuit. IC301’s output Pin 3 will remain active (+15V) for the entire discharge cycle. This time is adjustable by the RC time constant of C301 220 μ fd, R307 10K, and potentiometer POT301. This timer remaining active is what provides the delay between the discharge of the machine and the ability to recharge for the next cycle. Timer IC302 is used to provide a delay between the start of the discharge cycle and actual discharge of the capacitor banks to allow the charge circuit enough time to shut-off (approx.: 100ms). When IC302’s output returns to a low (timing cycle completed) C306 discharges and provides a trigger to IC303. Upon seeing the trigger the output of IC303 goes high (+15V) and turns on the second half of the “AND” circuit Q306. This allows the collector of Q305 to go low providing a low impedance path to ground (supply common) to be seen at Pin 2 of the header connector. Pin 2 of the header provides the start signal used to trigger the circuit board that drives the discharge device (typically an SCR driver board).

C. General Description Power Supply and Relay Board # 10401433

This board is a combination of two boards that can be separated from one another. When not separated, the board is part number 10401433. Once separated the two boards become a # 10401415 and # 10401416. All references to the header connector pin numbers of # 10401415 should be considered 1CN, and all references to the header connector pin numbers of 10401416 should be considered 2CN.

D. General Description of ± 15 VDC/ ± 24 VDC Power Supply # 10401415

To provide normal operation for this board an external transformer (36 VAC center-tapped) must be used. This board is used to supply unregulated ± 24 VDC and regulated ± 15 VDC. The +15 output is adjustable from approximately 6.5 VDC to 16 VDC and must be adjusted prior to use. The -15 output is not adjustable.

E. Technical Description of $\pm 15\text{VDC}/\pm 24\text{VDC}$ Power Supply # 10401415

The power supplied to this board must be provided by an externally mounted transformer connected to Pins 5 and 6, center tap to Pin 7 or 8, of header connector. This transformer should provide 18 VAC between Pins 5 and 7 or 8, and 18 VAC between Pins 6 and 7 or 8, 36 VAC should be seen between Pins 5 and 6. The center tap of this transformer is connected to circuit common. Full wave bridge rectifier DB 201 (1 amp max) serves to provide unregulated +24 VDC and -24 VDC with respect to circuit common approximately 50 VDC may be from the negative to the positive side of this bridge. The +24 VDC output (Pin 4 of header connector) is filtered by C202 (2200 μfd) and the -24 VDC output (Pin 3 of header connector) is filtered by C203 (500 μfd). The +24 VDC output also supplies the input to adjustable regulator IC 201 (1.5 amp max) to provide the +15 VDC output (Pin 1 of header connector). This regulator may be adjusted from approximately +6.5 VDC +16 VDC (with respect to circuit common) by POT 201 (500 Ω 1 turn). The -24 VDC output supplies the input to regulator IC 202 used to provide the -15VDC output Pin 2 of header connector. The ± 24 VDC outputs are non-regulated and will vary with input AC voltage and/or load. The ± 15 VDC outputs are regulated and should not vary more than ± 0.5 volts. The limiting factor for available output current may be dictated by the external transformer connected to this power supply. All of the components used are rated for a minimum of 1 Amp. However, if the transformer used is rated for less than 1 Amp, the rating of the transformer will dictate available output current.

F. General Description of Relay Board # 10401416

This board houses 2-4 Pole double throw 24 VDC (coil) relays. Each contact set on both relays is electrically isolated from each other.

G. Technical Description of Relay Board # 10401416

Relay CR201's coil and contacts run to Pins 15 through 28 of the header connector. Relay CR202's coil and contacts run to Pins 1 through 14 of the header connector. A diode is mounted in parallel with each relay coil to eliminate an induced surge generated by turning off the inductive load of the relay's coil. This diode also dictates the polarity with which each coil is powered. CR202's coil is connected to Pins 1 and 3 of the header connector. The diode in parallel with CR202 is D203. The anode of D203 is connected to Pin 1, and the cathode of D203 is connected to Pin 3 of the header connector. The polarity of the power used to turn on CR202 must make the diode (D203) reversed bias. (Pin 1 of the header connector must be negative with respect to Pin 3 of the header connector.)

The contacts of CR202 are as follows:

Header Connector	Contact
<u>Pin Number</u>	<u>Configuration</u>
7	Normally Open (N.O.)
5	Common (C.) (shared by Pins 7 & 8)
8	Normally Closed (N.C.)
6	N.O.
4	C. (shared by Pins 6 & 9)
9	N.C.
13	N.O.
2	C. (shared by Pins 13 & 10)
10	N.C.
12	N.O.
14	C. (shared by Pins 12 & 11)
11	N.C.

CR201's coil is connected to Pins 26 & 28 of the header connector. The diode in parallel with CR201 is D202. The anode of D202 is connected to Pin 26 and the cathode of D202 is connected to Pin 28 of the header connector. The polarity of the power used to turn on CR201 must make the diode (D202) reversed bias. (Pin 26 of the header connector must be negative with respect to Pin 28 of the header connector)

The contacts of CR201 are as follows:

Header Connector	Contact
<u>Pin Number</u>	<u>Configuration</u>
22	Normally Open (N.O.)
24	Common (C) (shared by Pins 22 & 21)
21	Normally Closed
23	N.O.
25	C. (shared by Pins 23 & 20)
20	N.C.
16	N.O.
27	C. (shared by Pins 16 & 19)
19	N.C.
17	N.O.
15	C. (shared by Pins 17 & 18)
18	N.C.

H. Description of 3000 / 300 Divider Board # 10407715

This board provides the reference voltage to the Charge Control board. This voltage is proportional to the capacitor bank voltage divided by approximately 10. The potentiometer on this board is used to set the maximum voltage of the machine. This has been factory preset and should not require adjustment unless the Charge Control board or the Voltage Control potentiometer are repaired or replaced.

I. Technical Description of 3000 / 300 Divider Board # 10407715

The high voltage side of the capacitor bank is connected to 1CN terminal 1, common or ground of the capacitor bank is connected to 1CN terminal 2 which is common with the output connector 2CN terminal 1 and the low voltage output is 2CN terminal 3. The high side of the divider is the four 4 Meg ohm resistors (R3, R4, R5, and R6) in parallel, yielding a total resistance of 1Meg ohm. The low side of the divider is the 100K ohm resistor (R7). The 20 K ohm potentiometer (PT1) allows adjustment of the absolute output voltage. The potentiometer should be adjusted for the desired level with the impedance of the circuit that this board drives connected.

J. General Description of Parallel SCR Driver Board # 10412049

Caution: This board is referenced to the high voltage potential of the Main Capacitor Bank any trouble shooting requires test equipment that is isolated from earth ground. Touching such isolated equipment while the machine is charged constitutes a definite shock hazard that may result in serious injury.

This board is used to simultaneously (less than 100 nano-seconds) provide the gate drive signal to an electrically matched pair of SCRs. The board contains isolated power supplies, for each driver circuit. A single optically isolated start input simultaneously triggers both output driver circuits. The board has two green LEDs to signify power is applied to each of the two driver circuits, and two red LEDs that indicate the gate drive signal has been supplied to the gates of the SCRs. This board also has an isolated voltage divider that is not used in the 942B.

K. Technical Description of Parallel SCR Driver Board # 10412049

This board contains two identical driver circuits and two identical negative bias circuits. The technical description will describe one of the two driver circuits, and one of the two negative bias circuits the other circuit works exactly the same but the circuit designations of the components are different.

Start Input Circuit

The start circuit input on this board requires an external 10 VDC to 15 VDC power supply. The positive of this supply is connected to 2CN terminal 1 and the negative of the supply is connected to 2CN terminal 3. This supply powers two open-collector NAND gates and two opto-couplers. Pull-up resistor R1 maintains a high logic level on the input of U1A pins 1 and 2. When a low logic level is applied to the start input 2CN2, the output of U1A pin 3 goes to a high logic level. The instant U1A pin 3 goes high, Capacitor C3 appears as a short circuit applying a high logic level to the input of U1B pins 6 and 7. R2 serves as a pull-down resistor to the input of U1B pins 6 and 7, and R2 in combination with the value of C3 sets the duration of the gate drive output signal. When the high logic level is applied to the input of U1B pin 6 and 7, the output of U1B pin 5 goes low. This low logic level pulls current simultaneously through the input of the two opto-couplers. As C3 charges the high logic level on the input of U1B decreases. When the voltage on the input of U1B falls below approximately 2/3 of its supply voltage, the output of U1B pin 5 returns to a high, turning off the two opto-couplers and thus turning off the gate drive output.

Driver Circuit

Input AC power to the board is connected to 1CN between terminals 1 and 3, power line ground is connected to 1CN terminal 2. This power feeds the primary of two isolation transformers T1 and T2. T1 supplies the power for both gate drive circuits, and T2 feeds a negative bias supply. T1's secondary is rectified by bridge rectifier D13 and filtered by capacitors C12 and C13. The green LED D15 indicates this driver's power supply is active. The start input to the driver circuit is applied via opto coupler U3. Pin 5 of U3 is tied to the positive side of the drivers power supply. When the opto coupler is turned on the positive of the supply is seen at pin 4. This turns on transistor Q3, Note: This and the rest of the transistors in the circuit act as switches turning completely on and off. When Q3 turns on, its collector goes to a low logic level which in turn, turns off Q1 allowing its collector to go to a high logic level. The high level on the collector of Q1 turns on Q7. When Q7 is turned on its collector goes low which turns on Q8. Q8 is the last stage of the driver circuit. Q8 uses the stored energy in C12 to drive the output that applies power to the gate of an SCR. The combination of R20, and R21 with parallel capacitor C11, shapes the output pulse to provide a "Hard Gate Drive" signal. In the first instant when Q8 turns on, C11 appears as a short circuit and a sharp rising edge of current approximately 5 amps is applied to the gate of the SCR. As C11 charges the current reduces to a steady state of approximately 2 amps known as the "Back Porch" of the "Hard Gate Drive" signal. This all happens in approximately 200 μ seconds.

Negative Bias Circuit

The secondary of T2 feeds the power supply for the negative bias circuit. T2's secondary is rectified by bridge rectifier D2 and filtered by capacitors C5 and C7. The positive of the bias supply is referenced to the negative side of the gate drive power supply. Resistor R6 limits the bias current to approximately 0.04 amps. Diode D14 is forward bias by the negative bias supply limiting the voltage to approximately 0.7 volts in the opposite polarity to that of the gate drive circuit. This insures that C11 discharges at the end of the gate drive output signal.

VI. SERVICE AND MAINTENANCE

Service and maintenance of this equipment requires trained personnel. Care is required for safety of service personnel. High Voltage is exposed with panels removed. This unit should be operated with the panels removed ONLY if absolutely required for repair.

A. General Instructions

The Model 942B Magnetizer is a combination of electrical and electronic components. Procedures consistent with safety and standard practices for each area should be used.

Regular service should be performed to insure proper connection of all terminals.

If water is used for cooling, all water connections should be inspected regularly for leaks or obstructions. A regular inspection of the drain will prevent component failure due to overheating.

B. Test Equipment

Portions of the circuitry in this machine are isolated from earth ground. Trouble-shooting and repair must be carried out by qualified personal using properly rated test equipment. Failure to do so may result in damage to the Magnetizer and/or test equipment.

C. Panel Removal

Panels should be removed only by trained personnel. Care must be used when removing panels. Panels should be removed only with equipment disconnected from the AC line. Always check the Capacitor Bank voltage prior to beginning any repair. If the voltage is not zero, discharge the capacitors in a safe and proper manner before proceeding.

D. Adjustments

Maximum voltage setting, power supply voltage, and minimum cycle rate adjustments are factory set and should not be tampered with in any way without consulting Magnetic Instrumentation, Inc.

E. Trouble Shooting

Prior to beginning any trouble shooting, all connections should be checked. This includes AC power to the electronics cabinet and water supply if required. All trouble shooting should be done at low voltage. If trouble-shooting assistance is required contact Magnetic Instrumentation Inc. service department at 317-842-7500 or email maginst@maginst.com.

VII. REPLACEMENT PARTS

DESCRIPTION AND CIRCUIT DESIGNATION

CONTROL PANEL PARTS			STOCK NUMBER
POWER ON CIRCUIT BREAKER	1CB	15A/240V CIRCUIT BREAKER 2 POLE	57900646
CONTROL POWER FUSE	1FU	.500 AMP 250V SB 3AG	57602609
POWER ON LIGHT	1LT	120V 25mA 3W	58700656
ANALOG PANEL METER	1M	0-3000 VDC (1MA FS)	59106037
VOLTAGE CONTROL POTENTIOMETER	1POT	2 K 10 TURN 2W	32700267
FUNCTION SELECT SWITCH	1S	3 POS"ON"TOGGLE SWITCH	55200548
CHARGE / MAGNETIZE LIGHT	2&3LT	24V 73mA 1.5W LAMP	58700654
CHARGE / MAGNETIZE PUSH BUTTON	1&2PB	PLUNGER SWITCH SENSITIVE	55606481
EXTERNAL CHARGE / MAGNETIZE SOCKET	1&2SOC	*2 PIN FEMALE SOCKET	63100731
EXTERNAL CHARGE / MAGNETIZE PLUG	1&2PLUG	*2 PIN MALE PLUG	63100725
POWER SUPPLY CHASSIS PARTS			
SAFETY DRAIN LOCKOUT RELAY	1CR	2PDT 25A 240VAC (120VAC)	52606627
SAFETY DRAIN RELAY	CRD	1PST N.C. 12A 10000V (26.5VDC) VAC.	52603004
DRAIN RESISTORS	3&4R	10 K 70/50W 5%	30505798
DRAIN RELAY CAPACITORS	12,13&14C	2200 uF 50 VDC CAPACITOR	35100310
DRAIN RELAY DIODES	12&13D	1000V 1 AMP DIODE	40403375
SOLID STATE RELAY	1SSR	SOLID STATE N.O. 110A480VAC,4-32VDC	52601633
CURRENT LIMITING INDUCTORS	1&2L	.021H CHOKE	60406508
CHARGING TRANSFORMERS	1&4T	120/240 TO 3000 VAC CHARGE XFORMER	60308101
CONTROL POWER TRANSFORMER	3T	117 VAC TO 36.0 VCT 550 Ma	60100686
CURRENT BIAS SUPPLY PARTS			
BIAS SUPPLY TRANSFORMER	2T	117 VAC TO 25.2 VAC 1 AMP (942)	60106500
BIAS SUPPLY DIODE	11D	1000V 1 AMP DIODE	40403375
BIAS SUPPLY FILTER CAPACITOR	10C	2900 uF 50 VDC CAPACITOR	35106497
BIAS SUPPLY CHOKE	3L	INDUCTOR CHOKE .8HY +25%-5%	60406501
BIAS SUPPLY RESISTOR	7R	25 OHM 50W 5%	30505802

CAPACITOR BANK AND DISCHARGE PARTS

			STOCK NUMBER
ENERGY STORAGE CAPACITOR BANK	1-8C	100 uF 3000 VDC W/G CAP.(9.25" TALL)	36112868
DUAL SCR (DISCHARGE DEVICE)	1SCR	4200V 2690A/20KA SCR ASM.	42613087
REVERSE CURRENT BLOCKING DIODE	1DDP	5000 V 17KA FAST RECOVERY DIODE SET	40412489

CIRCUIT BOARDS AND ASSEMBLIES

CHARGE CONTROL	1PCB	3000 VDC CHARGE CONTROL BOARD	10427655
CONTROL CIRCUITRY POWER SUPPLY	2PCB	POWER SUPPLY +-24, +-15 VDC W/RELAY	10401433
REFERENCE VOLTAGE DIVIDER	3PCB	3000/300 DIVIDER NETWORK BD.	10407715
PARALLEL SCR DRIVER	4PCB	PARALLEL SCR DRIVER CIRCUIT	10412049
CHARGING RECTIFIER ASSEMBLY	1&2SA	8883 DIODE BOARD ASSEMBLY	10007479
ANALOG METER RESISTOR ASSEMBLY	5SA	H.V.RESISTOR DIVIDER MT. 942A/9001	10008548

MISCELLANEOUS PARTS

SIDE PANEL FAN	1FAN	FAN 115VAC MINIATURE AXIAL	91001400
SIDE PANEL FILTER	92	FILTER 7"X 7"X 7/8"	91001402
MAGNETIZING FIXT. CONNECTION SOCKET	31	1 LARGE RECEPTACLE 747/942	63106512
SNAP RING FOR FIXT. CONNECTION SOCKET	25	RETAINING RING	20706506
CHARGE INTERLOCK MALE ON CHASSIS	24	LINE VOLTAGE JACK MALE	63206491
FEMALE MATE TO CHARGE INTERLOCK	1	250V 10A 2 WIRE RECP. CABLE MOUNT	62906245

NOTE: All parts for the Model 942B are available from Magnetic Instrumentation Inc.
 If a part that is not listed or trouble-shooting assistance is required contact the
 service department at 317-842-7500 or email maginst@maginst.com.